

Solid Modelling and Finite Element Analysis of Resilient Obelisk Winch (ROW) in Comparison with Tower Crane

KAPILESH.C¹, MOHAAN.T¹, PRANAV BALAJI.S^{1*}, SURESH.V¹

¹Graduate of Mechanical Engineering, Velammal Institute of Technology,
Chennai – Kolkata High Way, Thiruvallur - 601204, TamilNadu, India.

*Email – pranav.spb@gmail.com

Phone - +91-9840552305.

Abstract- Architecture explains the state of living for generations. Construction is the process of constructing an infrastructure or building. Construction process uses different types of machines and tools. One among them is tower crane which is used for the purpose of lifting heavy loads and to move them to places from its load centre. Though Tower crane which is primarily being used in construction sites, they tend to have some banes such as can lift limited loads due to counterweight, has toppling and swirling effect on them also they need more space to have free gyrating motion. In order to eliminate those problems and bring a new design compared to the existing one we have proposed one new model which can eliminate all the stumbles from the existing one. Our model represents the epitome and quintessential of safety and rigidity. It is primarily focused on the factors of exorbitant lifting capacity, riddance of counterweight and centered at safety factors. In order to support the claim of ours, the paper concentrates on design and analysis of the existing Tower crane in comparison with the ROW for the stress and deformation factors. Modeling and assembly of the designs were carried out through Solidworks and analysis of both structure were done using Ansys18.0 (FEA method). Two models of crane were compared initially for stress and deflection developed in the structure and the results of ANSYS 18.0 were validated using numerical method.

Index Terms- Gyration, Toppling and swirling effect, Stress, Deflection, exorbitant lifting capacity.

1. INTRODUCTION:

Tower crane is a large lifting device used on the construction sites for lifting and moving construction materials such as steel structures from one place to another. The operation involves moving the crane hook along the trolley in the jib from what is called a supply point to the demand point lifting the load. The requirement of contractors and builders is simple. They want the work to be completed in an efficient way (which by the way also includes cost efficiency) and must not consume a lot of time. This is what seems to be a basic demand which has lots of consequences and given that the parameters of the present model of tower crane seems irreconcilable with our needs. So we propose a model which was vaguely took from the industrial purpose bridge crane. This modified crane helps us to complete more

work in less time, in addition to its technological sophistication that it brings to the picture.

Our main objective is to eliminate the gyrating mechanism which is obviously a great problem in the places where there are many other buildings around the construction site. And yet several accidents occur while heavy weights were employed or it may happen due to twisting or toppling effect which happens because of incorrect lifting procedure and improper speed of work. Our second most important motive is to eliminate the counterweights usually placed in the crane. By this we could possibly reduce the risk factor during work. And we could lift heavy weights than the normal by implementing our crane model.

2. EXISTING TOWER CRANE:

Until now for the purpose of construction, Tower crane is being used everywhere. It is a T-shaped structure and usually used because it gives the best combination of weight lifting capacity and aerial view to perform the operation. It has two horizontal arms. One is called the jib and the other is the counter arm. The hook of crane is suspended from the trolley, which in turn is attached to the jib. Then there is this hoisting drum used for lifting the hook in the jib. The long horizontal jib is the part of the crane that carries the load. The counter-jib carries a counterweight, usually of concrete blocks.

The crane operator either sits in a cab at the top of the tower or controls the crane by radio remote control from the ground. In the first case the operator's cab is most usually located at the top of the tower attached to the turntable, but can be mounted on the jib, or partway down the tower crane.

3. DRAWBACKS OF EXISTING CRANE:

In the existing tower crane also because of the enormous height of the present tower crane toppling effect may occur, the cranes collapse and disaster occurs. Several disasters have been recorded in the history due to this toppling effect.

During this disaster period it also damages the buildings surrounding the construction site. The most adverse effect is that when the crane falls, it falls with heavy counter weight of up to 18 tons, which is fixed in the counter jib. And yet the maximum lifting at the end of the jib is very minimal.

The climbing tower crane installed in the elevator shaft, due to the mounting structure requirements, you must open a certain number of holes in the elevator shaft wall, bring some adverse effects to the main structure.

4. MAST CRANE:

Based on the facts that are gathered from the various report study on the loading and stress capacity of the existing tower crane, we have designed our model **MAST CRANE** and we

proposed this model for the cases where construction of building is a tedious process. It is also proposed for the construction of building within a short period of time and we are sure that our design can fulfill these purposes.

The tower crane is highly sensitive to the problem of overloading. Maximum weight can be lifted at the start of the jib i.e. near the column. Weight supplied at the extreme end of the jib is very less depending upon the height of the tower crane, and creates higher stress formation in the supports, joints and column. Keeping this along with several other factors, we have come up with a model called **MAST CRANE**.

The mast crane will have more stability and it in turn increases the weight lifting capacity of the crane, since four pillars are implicated in the design. It has no gyrating motion, so stress formation is considerably reduced. And also there is no need of counter weights. Since the stability of this design is more, better safety will be provided also results in more efficiency and reduces the time consumption considerably when compared to the existing crane. The lifting process is much easier, swifter and provides high safety the life and property.

5. STRUCTURE OF MAST CRANE:

The whole construction of this system is simple and efficient. The arrangement and position of components makes the system to function. Each and every component has its own property and responsibility. The proposed design comprises of four pillars above which two supports are placed. On these two supports the jib ends are placed. The jib is moved over this support by using rails and rack and pinion arrangement. The rack and pinion arrangement provides controlled motion of the jib providing high grip. All the four columns are designed to have individual foundation around the construction site. The jib is a triangular structure and the columns are square lattice structure. The jib, columns and supports are made with truss members.

6. MODELLING AND ANALYSIS:

6.1. Model Development:

Solidworks has been used as design processing tool. It was used as preliminary step for geometric sketching and following commands such as extrude, extrude cut, mirror, pattern and various other trivial commands were also executed to complete the 3D modelling. Solidworks enables to construct a proper and structured diagram pivoted around it.



Figure 1.3D model of mast crane in Solidworks

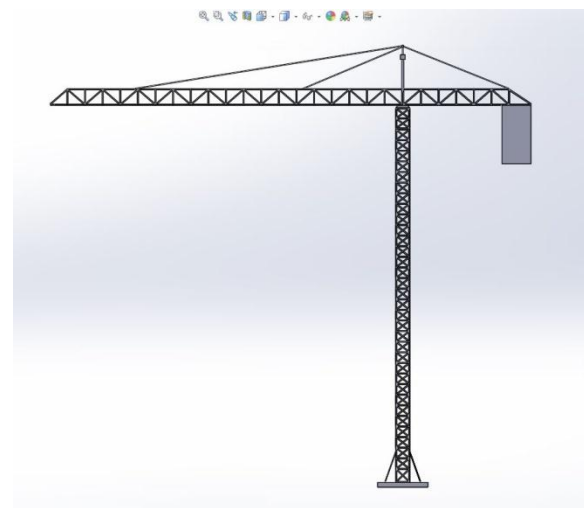

Figure2. 3D model of tower crane in Solidworks

6.2. Simulation tools:

In this study ANSYS workbench has been used as pre-processing tool. Analysis is accompanied with deformation, equivalent von mises stresses seeking solution from the momentum equation.

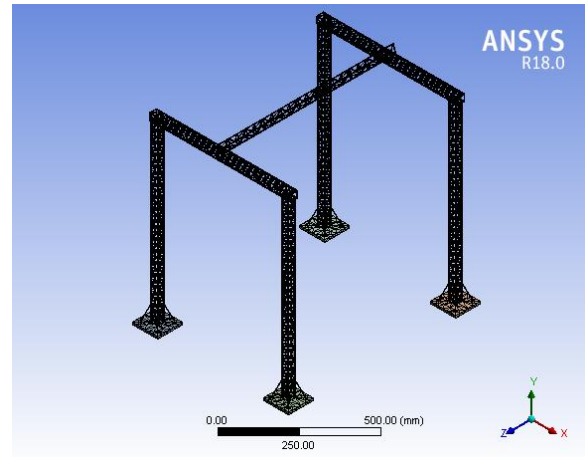

Figure 3.Mast crane after being meshed in ansys

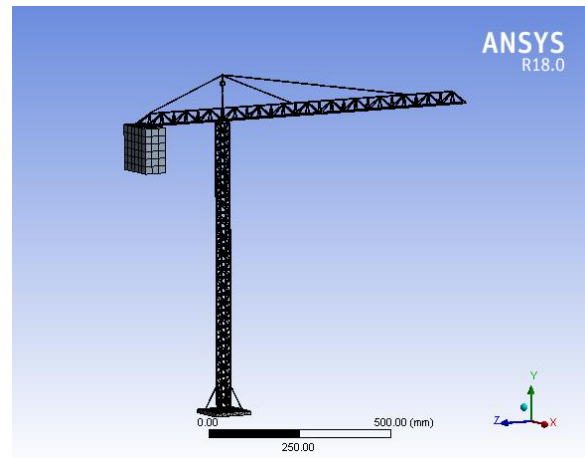

Figure 4.Tower crane after being meshed in ansys

7. DESIGN RATIO:

Prototype Tower Crane

Total jib length = Working jib + Counter jib

$$X = (70200 \text{ mm} \times 750 \text{ mm}) / 50000 \text{ mm}$$

$$X = 1053 \text{ mm (Total jib length)}$$

$$X_1 = (50000 \text{ mm} \times 750 \text{ mm}) / 50000 \text{ mm}$$

$$X_1 = 750 \text{ mm (Working jib)}$$

$$X_2 = (X) - (X_1) = 1053 \text{ mm} - 750 \text{ mm}$$

$X_2 = 303 \text{ mm}$ (Counter jib)
 (Total mast height for real time) / (Total mast height for prototype) = (1st brace strut for real time) / (L_1)
 (50000 mm / 5000 mm) = (750 mm / L_1)
 $L_1 = 75 \text{ mm}$ (Brace strut for prototype)
 Mast section height = Height – Brace strut
 = 750 mm – 75 mm = 675 mm
 (45000 mm / 3000 mm) = (675 mm / Individual mast section height)
 Individual mast section height = 45 mm
 No of remaining mast section = (Remaining mast section height / Remaining individual mast section height) = (675 mm / 45 mm)
 No of remaining mast section = 15
 Total number of mast section = Brace strut + remaining no of mast section = 1+15 = 16
 Total number of mast section = 16
 From standard tower crane manual# the following values have been derived

Parameters	Real Time Tower Crane in mm	Prototype Tower Crane in mm
Height	50000	750
Total jib	70200	1053
Working jib	50000	750
Counter jib	20200	303
Brace strut	5000	75
Mast section height	45000	675
Number of mast section	16	16
Mast cross section	2000×2000 ×3000	30×30×45
Counter weight	200KN	30KN

The dimensions of prototype mast crane is same as prototype tower crane for the height of 50m.

Real time to Prototype ratio

Brace strut real time = Brace strut prototype

$$5000 \text{ mm} = 75 \text{ mm}$$

Remaining individual mast section height real time =

Remaining individual mast section height prototype

$$3000 \text{ mm} = 45 \text{ mm}$$

$$(5000 \text{ mm} / 3000 \text{ mm}) = (3000 \text{ mm} / 45 \text{ mm}) \quad \text{Thus}$$

the real time prototype ratio is **1:66.67**

8. DESIGN ANALYSIS RESULT:

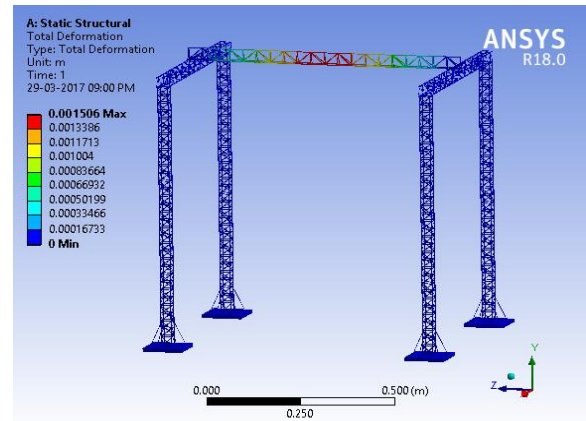

Figure 5. Centre load deformation of prototype

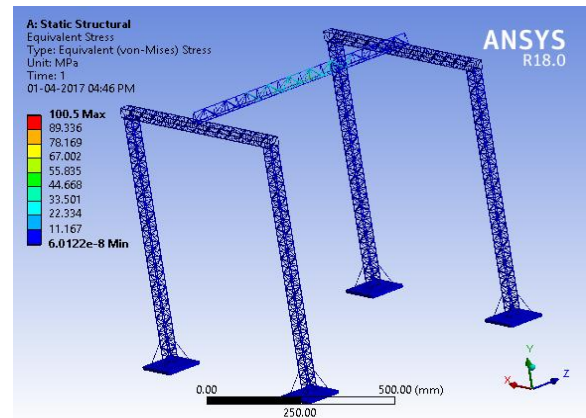

Figure 6. Centre load stress of prototype

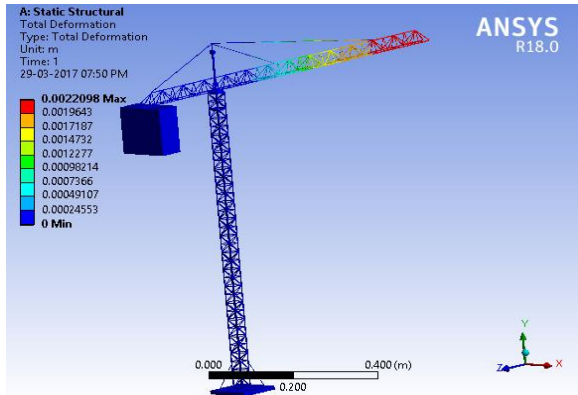

Figure 7. Centre load deformation of tower crane prototype

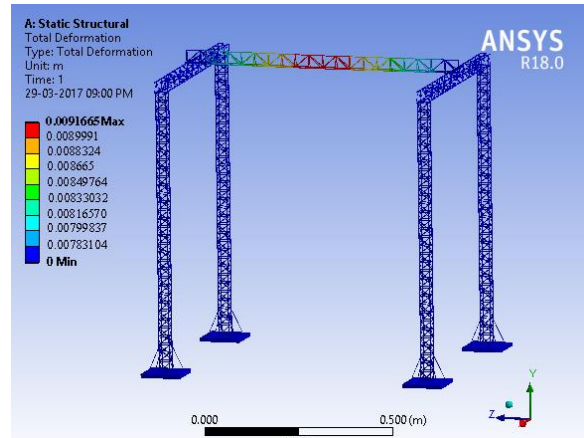

Figure 9. Centre load deformation of real time

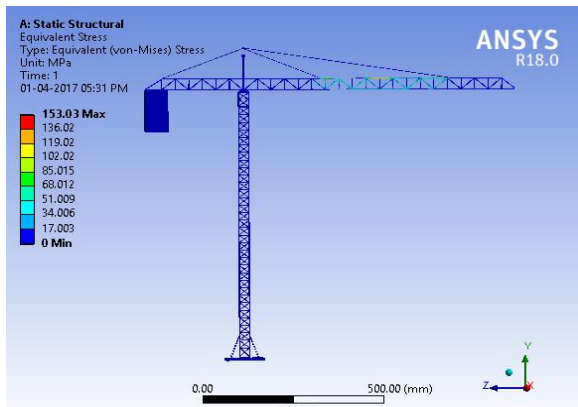

Figure 8. Centre load stress of tower crane

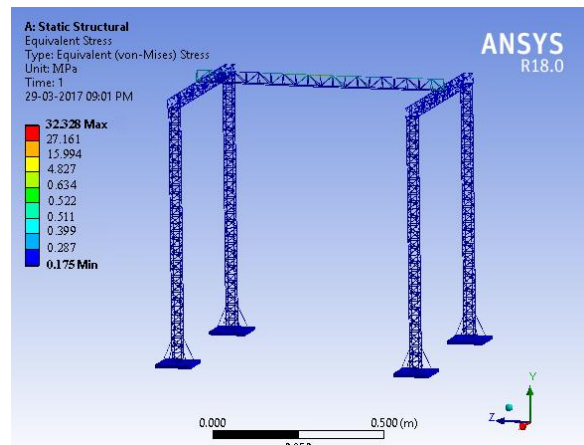

Figure 10. Centre load stress of real time

For the load of 100 N applied in the prototype of both mast crane and tower crane, the following results were obtained from Ansys

For a load of 100 N at the centre of the jib		
	Mast crane	Tower crane
Deformation(mm)	1.506	2.210
Stress(MPa)	100.5	153.0

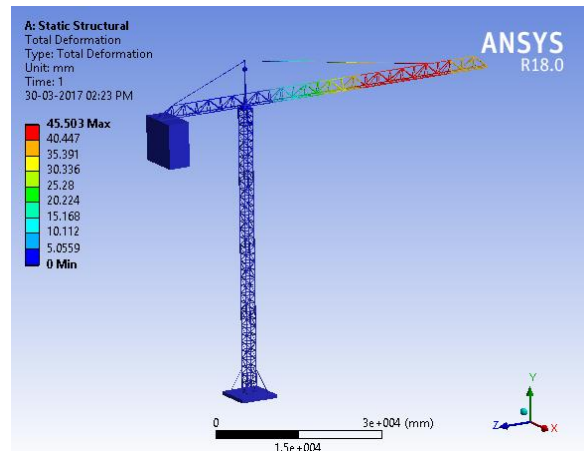

Figure 11. Centre load deformation of real time

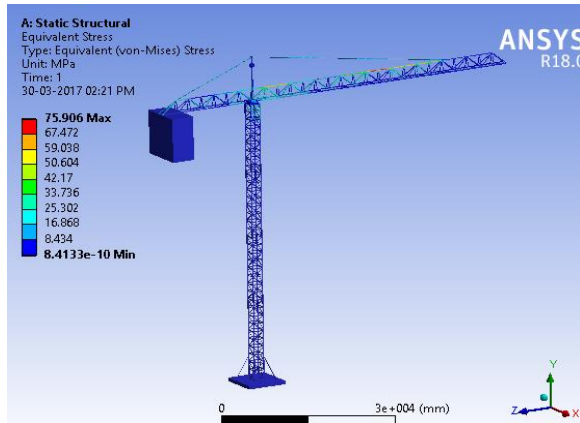

Figure 12. Centre load stress of real time

For the load of 100 KN applied in the realtime of both mast crane and tower crane, the following results were obtained from Ansys

For a load of 100 KN at the centre of the jib		
	Mast crane	Tower crane
Deformation(mm)	9.17	75.906
Stress(MPa)	33.328	45.50

Since the tower crane acts like a cantilever beam the end point can only bear less load when compared to other sections of jib from nearest tip of jib to a distance of 3.8m (in real time) from the mast. Thus for both Ansys and numerical analysis, for both prototype and real-time less load of 100N and 50000N is given as of in tower crane manual.

9. NUMERICAL ANALYSIS:

9.1 MAST CRANE PROTOTPE

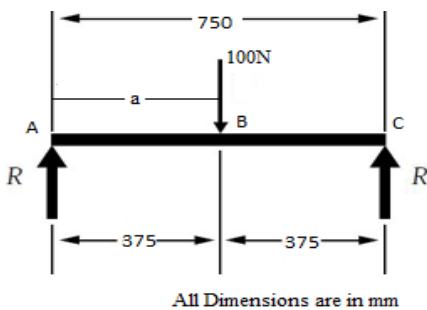

$$\text{Moment} = W * a = 50 \times 375$$

$$M = 18750 \text{ N mm}$$

$$\sigma = M/Z, Z = I/Y,$$

$$Y = D/2$$

$$Y = 35.25/2$$

$$Y = 17.625 \text{ mm}$$

Moment of Inertia

$$I = (BD^3/12) - (bd^3/12)$$

$$I = (21 * 35.2^3/12) - (20.29 * 34.07^3/12),$$

$$I = 9.77 * 10^3 \text{ mm}^4$$

$$Z = I/Y$$

$$= 9.77 * 10^3 / 17.625$$

$$Z = 554.32 \text{ mm}^3.$$

$$\sigma = M/Z = 18750 / 554.32$$

$$\sigma = 33.82 \text{ N/mm}^2$$

$$\text{Deflection } \delta = Wl^3 / 48EI$$

$$\delta = (100 * 750^3) /$$

$$(48 * 200 * 10^3 * 9.77 * 10^3)$$

$$\delta = 0.449 \text{ mm}.$$

9.2 TOWER CRANE PROTOTYPE

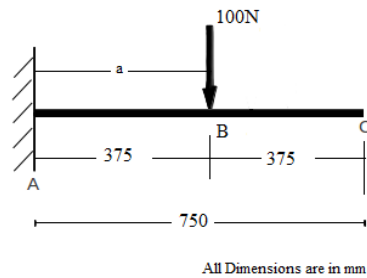

$$M = 100 * 375 = 37500 \text{ N mm}$$

$$Y = D/2 = 35.25/2 = 17.625 \text{ mm}$$

$$I = 9.77 * 10^3 \text{ mm}^4$$

$$Z = 554.32 \text{ mm}^3$$

$$\sigma = 37500/554.32 = 67.65 \text{ N/mm}^2$$

$$\delta = (Wa^3/3EI) + (Wa^2b/2EI)$$

$$\delta = (100*375^3/3*200*10^3*9.77*10^3)$$

$$+ (100*375^3/2*200*10^3*9.77*10^3)$$

$$\delta = 2.24 \text{ mm}$$

9.3 MAST CRANE REALTIME

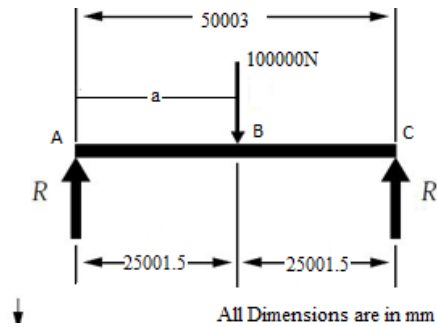

$$\text{Moment} = W * a = 50000*25001.5$$

$$M = 1.2501*10^9 \text{ Nmm}$$

$$\sigma = M/Z, Z = I/Y,$$

$$Y = D/2 = 2350/2 = 1175 \text{ mm}$$

Moment of Inertia

$$I = (BD^3/12) - (bd^3/12)$$

$$I = (1400*2350^3/12) - (1353*2272^3/12),$$

$$I = 1.916 * 10^{11} \text{ mm}^4$$

$$Z = I/Y = 1.916 * 10^{11} / 1175$$

$$Z = 163.06*10^6 \text{ mm}^3$$

$$\sigma = 1.2501*10^9 / 163.06*10^6$$

$$= 7.66 \text{ N/mm}^2$$

$$\text{Deflection } \delta = Wl^3/48EI$$

$$\delta = (100000*50003^3) / (48*200*10^3*1.916*10^{11})$$

$$\delta = 0.449 \text{ mm}$$

9.4 TOWER CRANE REAL TIME

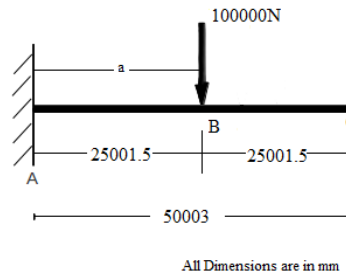

$$M = 100000*25001.5 = 2.50*10^9 \text{ Nmm}$$

$$Y = D/2 = 2350/2 = 1175 \text{ mm}$$

$$I = 1.916 * 10^{11} \text{ mm}^4$$

$$Z = 163.06*10^6$$

$$\sigma = 2.50*10^9 / 163.06*10^6$$

$$\sigma = 15.33 \text{ N/mm}^2$$

$$\delta = (Wa^3/3EI) + (Wa^2b/2EI)$$

$$\delta = (100000*25001.5^3/3*200*10^3*1.916*10^{11}) + (100000*25001.5^3/2*200*10^3*1.916*10^{11})$$

$$\delta = 33.98 \text{ mm}$$

10. COMPARISON OF RESULTS:

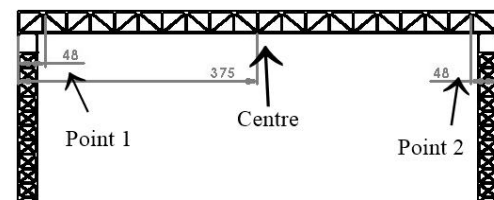

Mast Crane

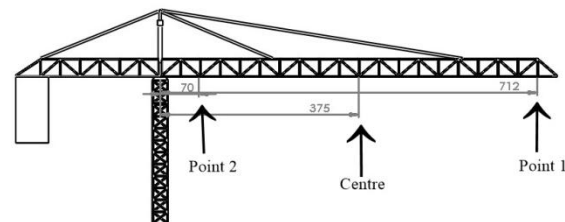

Tower crane

ANSYS RESULT COMPARISON OF PROTOTYPE			
Parameter	Load point at(100N)	Mast crane	Tower crane
Stress (MPa)	Point 1	35.4	279.54
	Mid Span	100.5	153.0
	Point 2	35.4	92.36
Deformation (mm)	Point 1	0.386	7.522
	Mid Span	1.506	2.210
	Point 2	0.386	0.147
ANSYS RESULT COMPARISON OF REALTIME			
Parameter	Load point at (100 KN)	Mast crane	Tower crane
Stress (MPa)	Point 1	19.673	46.40*
	Mid Span	33.328	75.906
	Point 2	19.673	21.393
Deformation (mm)	Point 1	4.188	58.73*
	Mid Span	9.17	45.50
	Point 2	4.188	4.345
NUMERICAL RESULT COMPARISON OF PROTOTYPE			
Parameter	Load point at (100 N)	Mast crane	Tower crane
Stress (MPa)	Point 1	8.105	128.44
	Mid Span	33.82	67.65
	Point 2	8.105	12.62
Deformation (mm)	Point 1	0.088	6.64
	Mid Span	0.449	2.24
	Point 2	0.088	0.09
NUMERICAL RESULT COMPARISON OF REALTIME			
Parameter	Load point at (100 KN)	Mast crane	Tower crane
Stress (MPa)	Point 1	1.83	14.56*
	Mid Span	7.66	15.33
	Point 2	1.83	2.86
Deformation (mm)	Point 1	1.33	50.14*
	Mid Span	6.79	33.98
	Point 2	1.33	1.38

* - From the given standards for the jib of tower crane it can only hold upto 5.3 tons for the height of 50 m. So we have given a load of 5 tons (50000 N) for the analysis of both real-time tower crane and mast crane for Ansys analysis and numerical calculations.

From the above analysis results and numerical calculations, we came to know that our mast crane performs better than tower crane in terms of load withstanding capacity and stability.

11. CONCLUSION

The Mast Crane will prove very effective in future. It overcomes most of the limitations of the tower crane. As from the result that Mast Crane has better stability, better weight lifting capacity. It also decreases any serious potential in construction. The time efficiency of tower crane is less compared to Mast Crane. There is no stress formation in the crane and hence there is no fear of buckling effect to a large extent.

The model is markedly a departure from the traditional tower crane. It will in the long run prove fruitful in the construction of fast projects. The presented model is a model and must only be treated as such. It's an attempt to look at alternatives and open choices so that necessary advancements in the field of construction can be done. That said the model presented might be good alternative to the traditional tower cranes in specific conditions. Further research might improve the prospects of the presented model.

12. SCOPE FOR FUTURE WORK:

Constructions and structures will be one of the everlasting one that a human has built so far. They will stand still and tall even after the demise of generations and generations. Those constructions should be made in a better stable and in quicker way to make work much easier. Our work basically focuses on those aspects and in terms of future scope, it could be tested out for real time prospects and then it can be proposed to construction companies in order to implement this new idea of concept which can bring out a better aspect of future construction of buildings.

REFERENCES

1. J. Jafari, M. Ghazal, M. Nazemizadeh “A LQR optimal method to control the position of an overhead crane” *International Journal of Robotics and Automation (IJRA)* Vol. 3, No. 4, December 2014, pp. 252~258 ISSN: 2089-4856.
2. Dianwei Qian and Jianqiang Yi “Design of Combining Sliding Mode Controller for Overhead Crane Systems”, *International Journal of Control and Automation* Vol. 6, No. 1, February, 2013.
3. Patel Ravin B, Patel Bhakti K., Patel Priyesh M, Patel Dixit H. “Design and analysis of crane hook with different material”.
4. Tarek Zayed, Najwa Abbas “Crane Safety in Construction Sites”, *International Journal of Architecture, Engineering and Construction* Vol 2, No 2, June 2013, 88-97.
5. Javier Irizarry, Ebrahim P Karan, “Optimizing location of tower cranes on construction sites through GIS and BIM integration”, *Journal of Information Technology in Construction - ISSN 1874-4753*
6. Ajinkya Karpe1, Sainath Karpe, Ajaykumar Chawrai “Validation of use of FEM (Ansys) for structural analysis of tower crane jib and static and dynamic analysis of tower crane jib using Ansys” *International Journal of Innovative Research in Advanced Engineering (IJIRAE)* ISSN: 2349-2163 Volume 1 Issue 4 (May 2014)
7. Zhang Yang, Zhao Jianzhi, Yao Junjun, “Static structural finite-element analysis of tower crane based on FEM”
8. Ismail Gerdemeli, Serpil Kurt, Okan Deliktas, “Finite Element Analysis of the Tower Crane”, 14th International Research/Expert Conference, Trends in the Development of Machinery and Associated Technology, 11-18 September 2010